

Car Park Control System by Microcontroller

Kay Khine Htun

Computer University (Patheingyi),

kkhinehtun14@gmail.com , khinkyu28@gmail.com

Abstract

PIC microcontroller has become a real powerhouse with regards to available support. In many ways, the PIC microcontroller has more support available than other electronic devices. Microcontroller is a complete computer control system on a single chip. In this paper, the design of the car park control system is provided. By the help of components, such as, PIC16F628A microcontroller device, Liquid Crystal Display (LCD), Photo Electronic Sensors, Diodes, the hardware and software technology are combined and developed in this system. This system is implemented by Assembly Language.

Keywords: Programmable Interface Controller, Liquid Crystal Display, Photo Electronic Sensor.

1. Introduction

Car park control system helps to minimize the manual performance. In the modern world, parking has taken centre-stage and in the era of miniaturization, it is become a very crucial necessity to avoid the wastage of time and manual performance in modern, big companies and apartments etc. PICs are popular with developers and hobbyists alike due to their low cost, wide availability large user base, extensive collection of application notes, available of low cost or free development tools, and serial programming (and re-programming with flash memory) capability. In this system, car park control system by microcontroller is constructed with PIC16F628A and software programming language is written by Assembly language [3], [4].

2. PIC Microcontroller

The heart of this system is PIC Microcontroller. Microcontroller is a chip, which contains CPU, memory, timer, input ports, output ports and work as

a computer. So microcontroller is a complete computer control system on a single chip. Microcontroller is essential for the operations of device such as mobile phones, DVD players, video cameras, and most self-contained electronic systems. Microcontrollers are more compact and powerful than normal analog devices. They can perform the required controlling system. The PIC microcontroller is the brain of the circuit controlling all action to be done. PIC can use program delete or update during the use at the circuit. These are many types of PIC microcontroller, but this system is implemented based on PIC16F628A [6].

2.1. PIC16F628A Microcontroller

PIC16F628A microcontroller is 18 pin enhanced flash-based, 8-bit CMOS microcontroller. To begin with, the PIC16F628A uses Harvard architecture in which program and data are accessed from separated memories using separate buses. PIC microcontrollers can operate from a power supply voltage in the range 2V to 6V. The standard power supply voltage in digital electronic circuit is 5V. PIC16F628A microcontroller is high-endurance Flash/EEPROM cell: 100,000 write Flash endurance, 1,000,000 write EEPROM endurance. PIC16F628A microcontroller is 40 year data retention. PIC16F628A peripheral features with the following:

- 16 I/O pins with individual direction control
- High current sink/source for direct LED drive
- Analog comparator module with:
 - Two analog comparators
 - Programmable on-chip voltage reference (V_{REF}) module
 - Selectable internal or external reference
 - Comparator outputs are externally accessible
- Timer 0: 8-bit timer/counter with 8-bit programmable prescaler
- Timer 1: 16-bit timer/counter with external crystal/clock capability

- Timer 2: 8-bit timer/counter with 8-bit period register, prescaler and postscaler
- Capture, Compare, PWM module:
 - 16-bit Capture/Compare
 - 10-bit PWM
- Addressable Universal Synchronous Asynchronous Receiver Transmitter USART/SCI [1].

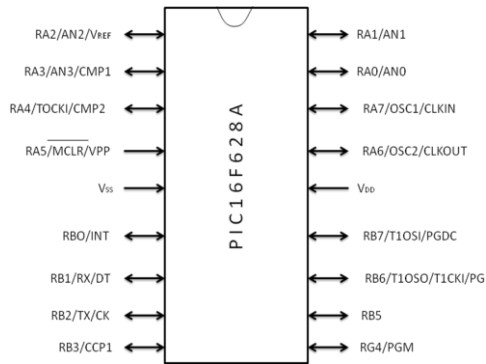

Figure 1. Pin diagram of PIC16F628A

3. Sensor

A wide variety of sensors are used in digital control systems and interfacing them requires a good understanding of linear amplifier design and signal conditioning techniques. A sensor is an essential device that responds to some environmental variable and converts it into electrical output. This signal may then need to be conditioned (filtered, amplified, attenuated, converted) to allow the microcontroller to receive the input in a usable form. In this system, when a car approaches the entry switch Photo Electronic Sensor sends data to PIC microcontroller. And also, when a car approaches the exit switch Photo Electronic Sensor sends data to PIC microcontroller [2].

4. Liquid Crystal Display

One of the best solutions for devices that require visualizing the data is the “smart” Liquid Crystal Display (LCD). LCDs ability to display not just numbers, but also letters, words, and all manner of symbols, makes them a good deal more versatile than the familiar 7-segment light emitting diode (LED) displays. LCD’s line length of 8, 16, 20, 24, 32 and 40 characters are all standard, in one, two and four-line versions. A 14pin access is provided, having eight data lines. This system uses 2 lines 16 characters LCD modules (1602A). Liquid Crystal Displays do not emit light, but they manipulate or reflect it. Thus they can display images using very little power. They reflect ambient light or reflect a

light source placed behind the LCD (called backlighting) [5], [7].

Table 1. Pinout function for all the LCD types

Pin No.	Name	Function
1	V _{ss}	Ground
2	V _{dd}	+ve supply
3	V _{ee}	Contrast
4	RS	Register select
5	R/W	Read/Write
6	E	Enable
7	D0	Data bit 0
8	D1	Data bit 1
9	D2	Data bit 2
10	D3	Data bit 3
11	D4	Data bit 4
12	D5	Data bit 5
13	D6	Data bit 6
14	D7	Data bit 7

5. Power Supply

The power supply is an important part of any electronic circuit. In this system, the step-down power transformer is used. First, the system gets 220V and 50Hz AC. Then, 220V AC steps down to 9V AC by using 9V step down transformer. The system uses 5V for LCD display and 16F628A PIC. So, 9V AC is converted to 9V DC by using full-wave bridge receiver power supply. Then, the system uses 9V DC to step down 5V DC. The power supply of the system is shown in figure 2.

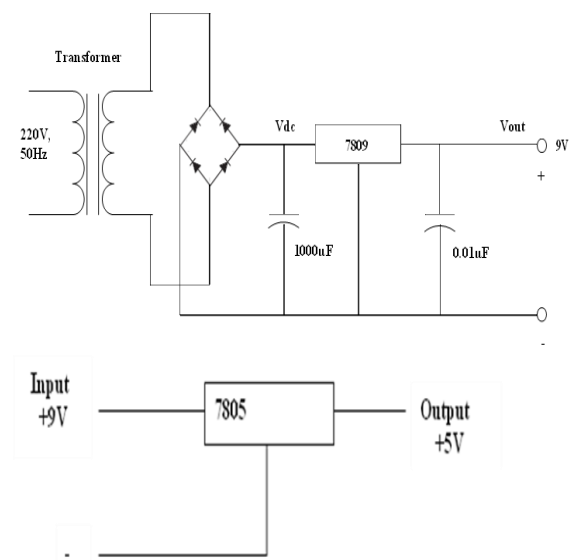

Figure 2. Power supply of the system

6. System Overview

The configuration (see figure 3) is car park control system. This system consists of three major components: PIC, LCD and sensors. Two switches are connected to the microcontroller inputs: entry switch and exit switch. These switches are operated, when a car approaches at the entrance and the exit of the car park. The system counts the different of the number of cars entering and leaving the car park and it can also test the parking. In this system, assume that the capacity of the car park is “5”. If the car park is empty (i.e there is no car inside the car park), then the message EMPTY is displayed. If a car passes the entry switch, the count increase to count+1 and the message count+1 is displayed. If a car passes the exit switch, the count decrease to count-1 and the message count-1 is displayed. If the car park is full (i.e there are “5” cars inside the car park), then the message FULL is displayed. After displaying FULL message, the message LOCK is displayed when a car passes the entry switch.

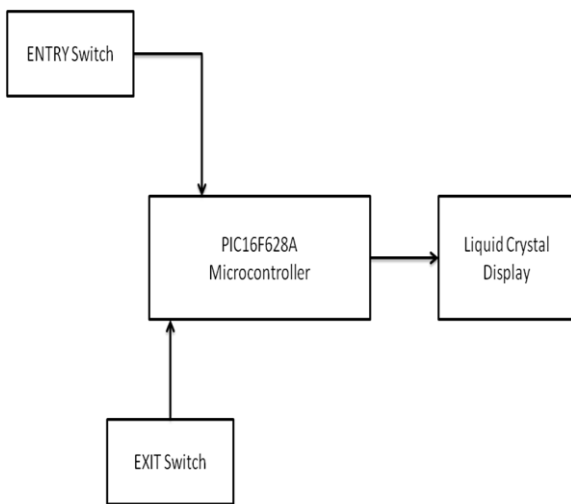

Figure 3. Overview of the system

7. Implementation of the system

The heart of this system is PIC Microcontroller. This system use “PIC16F628A” Microcontroller. In this system, Input ports are RA0 and RA1.

RA0 set ENTRY switch

RA1 set EXIT switch

Output ports are RB1, RB2, RB4, RB5, RB6 and RB7.

RB1 set LCD’s Enable pin

RB2 set LCD’s Register/Select pin

RB4 set LCD’s Data Bit 4

RB5 set LCD’s Data Bit 5

RB6 set LCD’s Data Bit 6

RB7 set LCD’s Data Bit 7

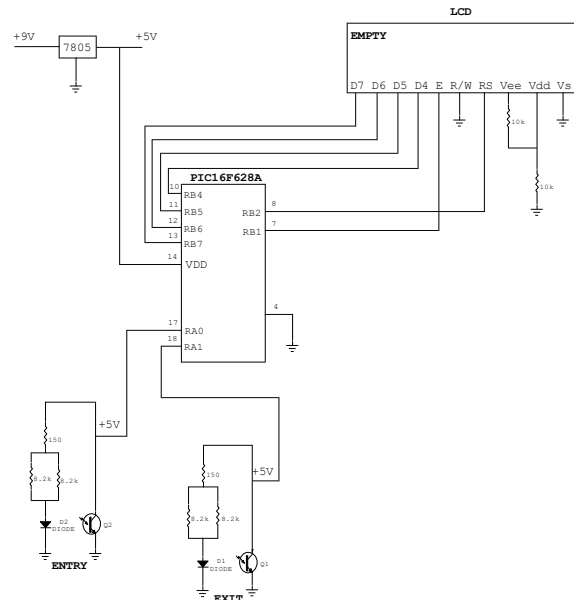

Figure 4. Circuit diagram of the system

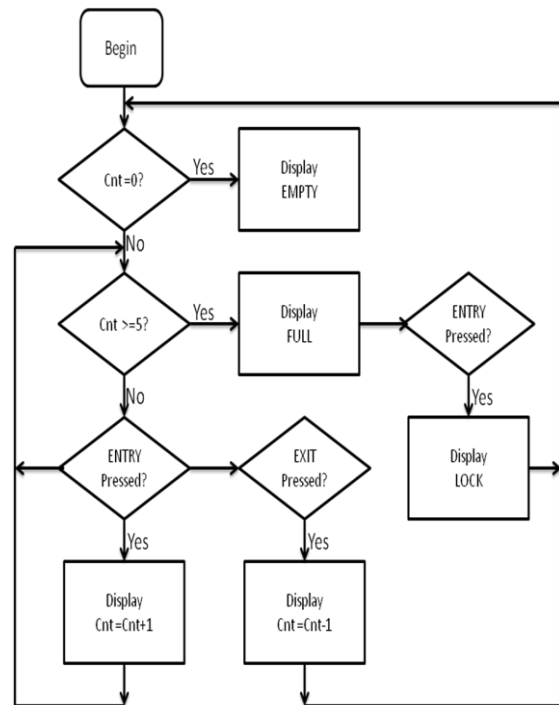

Figure 5. Flowchart of the system

The firmware program for the microcontroller is written by Assembly language that control hardware including sensors and display on LCD. A circuit diagram for PIC microcontroller hardware is given in figure 4. A flow diagram for PIC microcontroller software is given in figure 5.

Two switches are connected to the microcontroller inputs: entry switch and exit switch. These switches

are operated, when a car approaches at the entrance and the exit of the car park. The system counts the different of the number of cars entering and leaving the car park and it can also test the parking. In this system, assume that the capacity of the car park is "5". If the car park is empty, the message EMPTY is displayed (see figure 7). If a car passes the entry switch, the count increase to count+1 and the message count+1 is displayed. If a car passes the exit switch, the count decrease to count-1 and the message count-1 is displayed (see figure 8). If the car park is full, the message FULL is displayed (see figure 9). After displaying FULL message, the message LOCK is displayed when a car passes the entry switch (see figure 10). This system uses 2 lines 16 characters LCD modules (1602A) to display the result messages.



Figure 6. Car park of the system

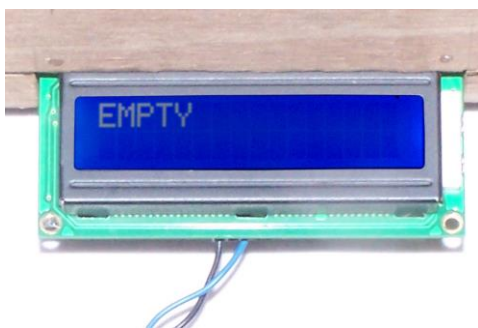

Figure 7. LCD displayed is EMPTY

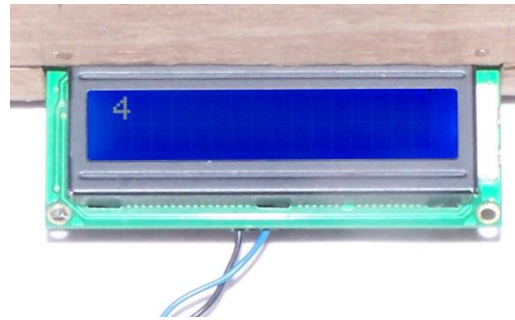

Figure 8. LCD displayed is count numbers

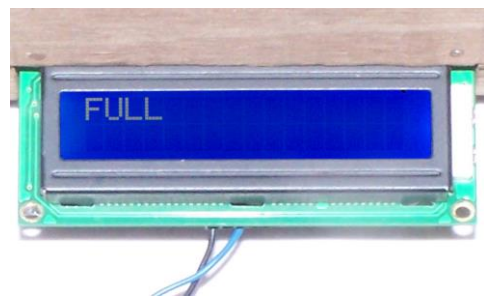

Figure 9. LCD displayed is FULL

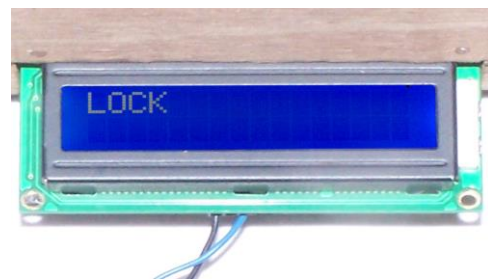

Figure 10. LCD displayed is LOCK

8. Conclusion

This system develops the car park using the advanced microcontroller PIC technology. It includes the hardware design and software implementations. This system can complete without using human being. The program checks the entry switch and the exit switch. Count is increased when a car enters the car park; count is decreased when a car leaves the car park. In this system, assume that the capacity of the car park is "5". Can changes the capacity depended on the using area. Based on this system, can operate by meaning of motor at entry switch and exit switch. By using motor can be locked, when LCD "LOCK" message is displayed. In real-world can be used, such as hotels, hospitals,

plazas and restaurants. The firmware program for the microcontroller is written with Assembly language that control hardware including sensors and display on LCD.

9. References

[1] Microchip Technology, Inc.2005, *PIC16F628A Data Sheet*, www.microchip.com

[2] Martin Bates, *Interfacing PIC Microcontrollers Embedded Design by Interactive*, 2006

[3] Win Htet Win, *PIC Microcontroller Projects, Part 2*, 2005

[4] Dogan Ibrahim, *PIC Basic Projects*, 2006

[5] Julyan Ilett, *Everyday Practical Electronics*, February 2007

[6] www.microchip.com

[7] www.lcdfriends.com