

Computerized Thermometer Using PIC and RS232 Interfacing

Thet Swe Win

University of Computer Studies (Mandalay), Myanmar
carpricon17@gmail.com

ABSTRACT

This paper aims to develop a computerized thermometer using PIC and RS232 serial interfacing. The analogue temperature sensor is used to detect the real world temperature. The temperature sensor produces analogue changes in voltage with respect to the detected temperature. These changes in voltage are applied into the microcontroller. The analogue to digital converter in the microcontroller digitizes the detected temperature. The microcontroller outputs the encoded temperature values in the form of RS232 compatible frames format. The level converter circuit converts the microcontroller's output voltages into the voltage levels of RS232 serial interfacing. The computer system reads the RS232 port and produces the screen readout of the detected temperature. The temperature can be obtained in degree Celsius as well as in degree Fahrenheit.

1. INTRODUCTION

An embedded controller is a computer that's dedicated to be smaller and less complex than PCs. Many are built into or embedded in, the devices they control. An embedded controller may have no keyboard or display and may be invisible to its users.

The CPU, or computer chip, in an embedded controller may be the same microprocessor found in PCs, or it may be a microcontroller, which is a computer chip designed specifically for use in control tasks [1].

Microcontroller chips come in many varieties: 8-bit chips have an 8-bit data path and are popular for use in monitoring and control link, but 4-, 16-, and 32-bit chips are also available. Different chips have different features and abilities, including serial ports of various types, varying amounts of memory for storing programs and data, and low-power modes for battery-powered circuits. A monitoring and control link can use any microcontroller that can connect to the desired interface [1].

2. BACKGROUND THEORY

2.1. RS232 Interface

The RS-232 interface is the Electronic Industries Association (EIA) standard for the interchange of serial binary data between two devices. It was initially developed by the EIA to standardize the connection of computers with telephone line modems. The standard allows as many as 20 signals to be defined, but gives complete freedom to the user. Three wires are sufficient: send data, receive data, and signal ground. The remaining lines can be hardwired on or off permanently. The signal transmission is bipolar, requiring two voltages, from 5 to 25 volts, of opposite polarity.

RS232 is designed to handle communications between two devices, with a distance limit of 50 to 100 feet, depending on the bit rate and cable type. Because RS232 ports are so common, another popular use is to connect to an adapter that converts the interface to another type.

RS232 links use unbalanced lines. Although a states of unbalance sounds like something to be avoided. In an unbalanced line, the signal voltage is applied to one wire, and all signal voltages are referred to a common ground. Another term for this type of interface is single-ended. In contrast, in the balanced, or differential, each signal uses

two wires, with one wire carrying the inverse of the other. Table 1 shows the nine signals use in PC and many other devices [1].

Table 1. The PC's Serial Port and Nine Signals

Type	Signal	Description	Source	Pin (9 pin)
Control	CD	Carrier detect	DCE	1
	DTR	Data terminal ready	DTE	4
	DSR	Data set ready	DCE	6
	RTS	Request to send	DTE	7
	CTS	Clear to send	DCE	8
	RI	Ring indicator	DCE	9
Data	RD	Received data	DCE	2
	DT	Transmitted data	DTE	3
-	GND	Signal Ground	-	5

2.2. PIC 16F877A Microcontroller

A PIC microcontroller is virtually a complete computer on a single chip. A microcontroller contains in one integrated-circuit (IC) package are the CPU, ROM, RAM, a serial interface, timer and several input/output lines. Microcontrollers are often called embedded controllers because they are used as a component of a larger system. It is a fairly basic computer in comparison to the average PC, but for many purpose. The PIC devices are simple but streamlined processors that are specifically intended for general control and measurement application, and they work very well when used for suitable tasks.

A clock oscillator controls the rate at which instructions are executed, and PIC processors can operate over a very wide range of clock frequencies. In fact, a RISC processor normally completes more instructions in just one clock cycle. The clock speed of PIC microcontroller is up to 20MHz is normally used. An innovative modular hardware and software design allows PIC to be expanded easily and efficiently. Because of having low costs, less circuitry, low power consumption and higher technologies, we choose the PIC to update our applications.

PIC16F877A microcontroller is used to implement the system. That has only 35 single-word instruction to learn. All single-cycle instructions except for program branches, which are two-cycle. Operating speed is DC-20 MHz clock input. Flash program memory is up to 8K x

14 words and data memory (RAM) is up to 368 x 8 bytes and EEPROM data memory is 256 x 8 bytes [2].

3. LM35DZ TEMPERATURE SENSOR

The LM35 series are precision integrated-circuit temperature sensors, whose output voltage is linearly proportional to the Celsius (Centigrade) temperature. The LM35 thus has an advantage over linear temperature sensors calibrated in °Kelvin, as the user is not required to subtract a large constant voltage from its output to obtain convenient Centigrade scaling. Internal Structure of the LM35DZ temperature sensor is shown in Figure 1.

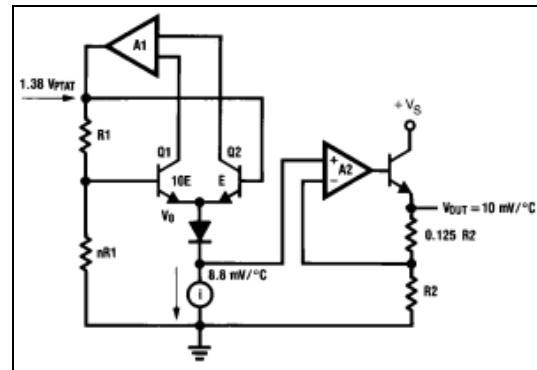

Figure 1. Internal Structure of the LM35DZ Temperature Sensor

The LM35DZ can be applied easily in the same way as other integrated-circuit temperature sensors. It can be glued or cemented to a surface and its temperature will be within about 0.01°C to the surface temperature.

Like most micro power circuits, the LM35 has a limited ability to drive heavy capacitive loads. The LM35 by itself is able to drive 50pf without precautions. If heavier loads are anticipated, it is easy to isolate or decouple the load with a resistor or can improve the tolerance of capacitance with a series R-C damper from output to ground.

However, as with any linear circuits connected to wires in a hostile environment, its performance can be affected adversely by intense electromagnetic sources such as relays, radio transmitters, motors with arcing brushes, etc, as its wiring can act as a receiving antenna and its internal junctions can act as rectifiers [3].

In this system LM35DZ TO-202 plastic package is used. The sensor is connected to bit 0 of PORTA (AN0).

4. DESIGN AND IMPLEMENTATION

This system consists of a temperature sensor, a PIC microcontroller, a MAX232 level converter IC and an RS232 line.

The analog temperature sensor is used to detect the temperature. The output analogue values of the temperature sensor are applied into the microcontroller. The microcontroller contains the built-in A/D converter. The built-in A/D converter converts the analogue temperature values to the digital values. The microcontroller produces the temperature value in the RS232 frame format. In an asynchronous RS232 communication, a frame consists of a start bit, 7 or 8 data bits, an even or odd parity bit, and a stop bit. In many applications, a 10-bit frame is used to send a data byte with the following characteristics:

- 1 stop bit
- 8 data bits
- no parity bit
- 1 stop bit

Typical baud rates are: 2400, 4800, 9600, 19,200, 38,400, etc.

The output voltage levels of the microcontroller are TTL voltages. RS232 voltage levels of the computer system are CMOS levels of $\pm 12V$ where $-12V$ is called Mark (logic 1) and $+12V$ is called Space (or logic 0). Normally, the output voltage levels of the microcontroller are converted to CMOS levels using RS232-level converter chip. The RS232-level converter chip converts the 0 and +5 V output from the microcontroller into $\pm 12V$ RS232 levels. Similarly, the RS232-level output is converted into 0 and +5 V suitable for the microcontroller inputs.

Normally, RS232 voltage levels are converted to CMOS levels using RS232-level converter chips such as the MAX202, MAX232, DS275, etc.

MAX232 level converter IC is a 16-pin IC having dual RS232 transmitters and receivers. This IC requires external capacitors for its operation. That can operate up to 120kbit/s and has two driver and two receivers [4].

The computer system reads out the RS232 frames to obtain the temperature and displays on the screen in degree Celsius as well as in degree Fahrenheit.

The system is connected to a serial line such as the COM1 or COM2 port on a PC. The communication parameters should be set to 2400 Baud, 8 data bit, 1 start bit, 1 stop bit, and no parity bit.

The circuit diagram of the system is shown in Figure 2. Any type of PIC microcontroller with a built-in A/D converter can be used. In this system, a PIC16F877A-type microcontroller is used. This is a popular microcontroller having 40 pins and 8 channels 10 bit multiplexed built-in A/D converter.

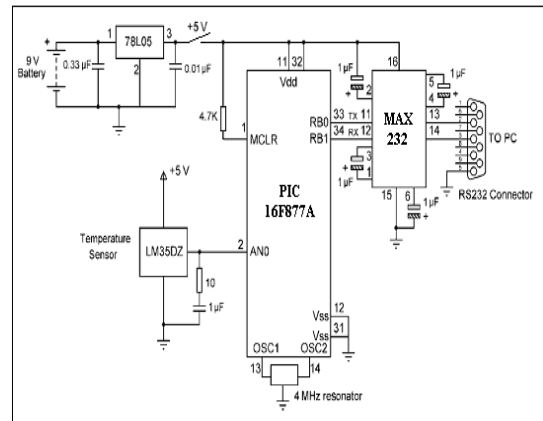

Figure 2. The Circuit Diagram of The System

The flow diagram of the system is shown in Figure 3. When the program starts, it declares the including files and RAM usage of PIC microcontroller. Symbols RS232_out and RS232_in are assigned to 0 and 1, respectively which denote RB0 and RB1. PORTA and PORTB directions and A/D are then configured. The user chooses the degree Centigrade(C) or degree Fahrenheit(F) and sampling interval time. The system checks the received data that is the sampling interval time in seconds from serial port, then accept the control data from computer.

When the microcontroller is powered up, the RS232 port output may be logic 0 and this may cause some unwanted data to be sent to the receiving device. In order to avoid this, RS232 port output (RB0) is set to logic 1 for about 100ms.

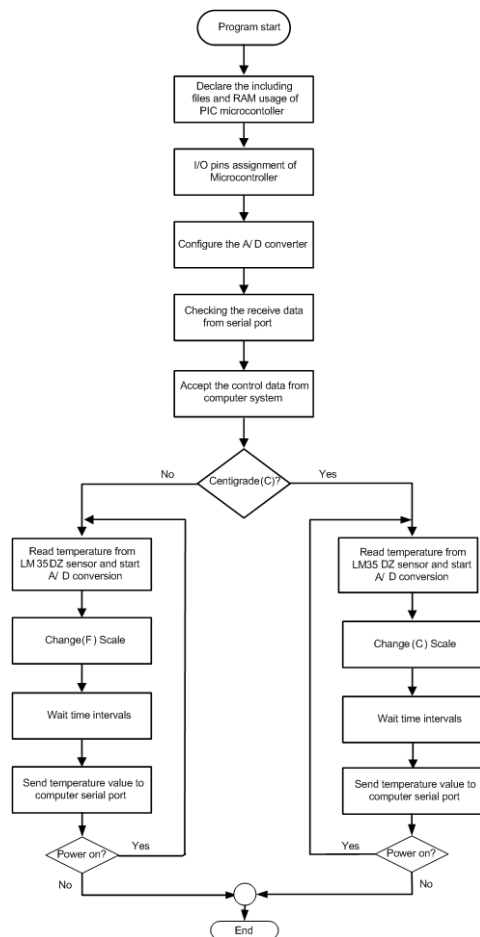

Figure 3. Flowchart of the System

Serial outputs are sent using the SEROUT statements. Similarly, serial inputs are received using SERIN statements. When the temperature is read from the LM35DZ sensor, converted into analog to digital by using A/D function of PIC. The digitized value is depends on the selected mode ($^{\circ}\text{C}$ or $^{\circ}\text{F}$) and then sent to the RS232 port of the microcontroller. The program then displays the temperature value on the screen until the selected mode or sampling interval time is changed.

5. CONCLUSION

The aim of this system is to obtain temperature value from real world, by using PIC16F877A, RS232 communication interface and LM35DZ temperature sensor. PIC can change the analog to

digital value where the temperature sensor is sensed.

Three main components are used in this system: PIC16F877A, LM35DZ temperature sensor, and MAX232 level converter to obtain the temperature.

The LM35DZ temperature sensor is easy-to-use temperature sensors with excellent linearity. These sensors can be used with minimal external circuitry for a wide variety of applications and do not require any elaborate scaling schemes nor offset voltage subtraction to reproduce the Fahrenheit and Celsius temperature scales respectively.

The MAX232 is a dual driver/receiver that includes a capacitive voltage generator to supply TIA/EIA-232 voltage levels from a single 5-V supply. Each receiver converts TIA/EIA-232 inputs to 5-V TTL/CMOS levels.

However, this system demands some unique computer science skills, such that microcontroller programming, integration / interfacing, the design and construction of hardware and PIC to hardware communication and the communication between computer and devices using over RS232 interfacing technique are required to be mastered.

The design presented in this paper covers computerized thermometer that can be upgrade and maintained with the minimum of complexity and cost. Further goal of this design could enable the user to know the usage of PIC microcontrollers, and RS232 interface.

REFERENCES

- [1] Jan Axelson, *Serial Port Complete, Programming and Circuits for RS232 and RS485 Links and Networks*, Lakeview Research, 5310 Chinook Ln, Madison, USA, 2000.
- [2] *PIC 16F87XA Datasheet*, Microchip Technology Incorporated, 2355 West Chandler Blvd, USA, 2003.
- [3] "LM35/ LM35A/ LM35C/ LM35CA/ LM35D Precision Centigrade Temperature Sensors", National Semiconductor America, November 2000.
- [4] "Max232/232I Dual EIA-232 Drivers /Receivers", *SLLS047L*, February 1989-Revised March 2004.