



**PROCEEDINGS OF  
THE SECOND INTERNATIONAL CONFERENCE  
ON  
SCIENCE AND ENGINEERING**

*Volume - 1*

**Electronics  
Electrical Power  
Information Technology  
Engg: Physics**

**Sedona Hotel, Yangon, Myanmar  
December 2-3, 2010**

**PROCEEDINGS OF THE  
SECOND INTERNATIONAL CONFERENCE  
ON  
SCIENCE AND ENGINEERING**

**Organized by  
Ministry of Science and Technology**

**DECEMBER 2-3, 2010  
SEDONA HOTEL, YANGON, MYANMAR**

# Good Performance Video Camera Based Surveillance System

Moh Moh Khaing<sup>#1</sup>, Zaw Min Naing<sup>\*2</sup>, Clement Saldanha<sup>#3</sup>

<sup>#</sup>Department of Electronic Engineering, Technological University (Toungoo)

Technological University (Maubin), Myanmar

<sup>1</sup>mmoh.khaing@gmail.com

**Abstract**—This research is intended to develop video camera based surveillance system with low cost and good performance. The system is composed of a security camera and a personal computer based main control and monitoring. The target area campus of building can be monitored by the system. The main processing engine of the system is a program. The software system is composed of some functions and routines. Required components are: video camera interfacing, image acquisition and video signal processing from incoming video sequences for real time application. Furthermore, dynamic image analysis and GUI interfacing are important features of programming.

**Keywords**— Webcam, interfacing, image monitoring and detection, video signal processing, MATLAB

## I. INTRODUCTION

Surveillance system is the process of monitoring the behavior of people, objects or processes within systems for conformity to expected or desired norms in trusted systems for security or social control. Security has to be compared and contrasted with other related concepts: Safety, continuity, reliability. The key difference between security and reliability is that security must take into account the actions of active malicious agents attempting to cause destruction. Since automation and technology are developed, surveillance system are trended to high technology such as microcontroller, computer based and automated alarm network system such as wireless sensor network. Types of security mechanisms can be separated depend on nature, usage and scope of application fields. Some systems are for local area use and some are wide area use. They are traditional man power system, automation and sensor based system, sensor network based system and video based surveillance system.

Monitoring, checking and alerting process are basic processes for a surveillance system. For this surveillance system, five elements are considered. They are scene or environment, camera, transmission medium, control software and monitor. The scene is the area of surveillance. The camera is for image acquisition. The transmission medium carries the signal of the image acquisition device to the monitor. The control software is needed for the desired operation and the monitor for displaying the transmitted image. Fig. 1 shows a simple surveillance system.

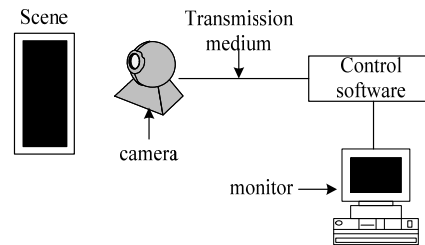

Fig. 1 A simple video surveillance system

## II. SYSTEM OVERVIEW

The main task of this research is to develop a surveillance system by using a video camera and software development. The detailed block diagram of the video camera based surveillance system is illustrated in Fig.2. In this system, a WebCam is used through USB port. The frame size of video image is 320×240 pixels and the frame rate is 30 frames per second. This frame rate is enough to detect normal life motion. Normally, any video camera can be used for this application. Frame rate and accuracy resolution of camera can affect the performance of application. Acquired images through driver adaptor are analyzed by frame per frame in every shot. A motion detection algorithm is developed by Matlab functions. The graphical user interface (GUI) is designed for testing of motion detection for surveillance purpose. The important property of this software is that the results of tests can be seen quickly and can be saved safely on a disk. And the user can manage the operation of the system through GUI.

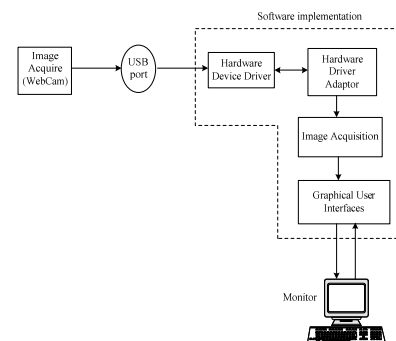

Fig. 2 Block diagram of the surveillance system

### III. FUNCTIONS OF THE SYSTEM

The image acquisition toolbox is a collection of functions that extend the capability of MATLAB. The toolbox supports a wide range of image acquisition operations, including acquiring images through many types of image acquisition devices, such as frame grabbers and USB PC cameras, also viewing a preview of the live video displayed on monitor and reading the image data into the workspace directly. For this project, **videoinput** function is used to initialize a video object that connects to the PC camera directly. Then **preview** function is used to display live video on the monitor. **getsnapshot** function is used to read images from the camera and place them in workspace.

All read images are converted into gray scale images by **rgb2gray** function. This is because equations in algorithms in the system are designed with such image format. Then by using **imabsdiff** function, SAD algorithm starts to compare the difference of two adjacent images by looping one pixel per another.

Then, the difference value is compared with threshold value. If the difference is greater than the threshold, motion is detected and all log, alarm parameter are set. The detected images are also logged and shown in frames by **imshow** function.

The sequence of graphs can be saved as a short movie that can then be played back using the **movie** function. Matlab can export a movie by saving it **.mat** file format. Movies are better suited to situations where each frame is fairly complex and cannot be redrawn rapidly. Each movie frame can be created in advance so the original drawing time is not important during playback, which is just a matter of blitting the frame to the screen. A movie is not rendered in real time; it is simply a playback of previously rendered frames. **Save** function is used for later information. And then create the audio/video interleaved (AVI) movie from Matlab movie to view the frames in any standard media player.

### IV. PROCESS DESCRIPTION OF SOFTWARE IMPLEMENTATION

The video object is part of the image acquisition process but it should be setup at the start of the program. The program starts with general initialization of software parameters and objects setup. After initializing the video object, the program checks the flag value which indicates whether the surveillance operation is started or not. If the value is set, the program begins reading the images. If motion is detected, it starts the process of calculations and then goes back to next image. Whenever the operator stops the operation, the value of the flag is set to zero. And then memory is clear and necessary results are recorded.

General processing flowchart is depicted in Fig.3. The follows are the operation steps of the system.

1. Initialize video object
2. Capture the first frame as image-1
3. Capture the second frame as image -2
4. Compute the difference between two images

5. Compare the difference with threshold value
6. If difference > threshold, log message and display image and then read the next image
7. Else, read the next image

Capturing image is based on the video camera and interfacing. The system is demonstrated on the video sequences (320×240 pixels per frame, 30 frames per second) taken from the commercial low-cost video camera. From the video frame sequences, motion in the scene will be detected for surveillance purpose. To detect motion in the target area, image differencing technique is applied. Firstly, two successive images from video camera are taken to the MATLAB workspace and must be converted to gray scale image for differencing. And then pixel difference is manipulated in order to detect the movement in the specified area. If the variance of the two most recent images is larger than the value of the preset threshold, the second image is captured as detected image. At the same time, this image is logged and displayed on monitor with true color. The motion data are needed to record for future analyzing. In this system, whether motion is present in the field of view or not is based on the sensitivity threshold.

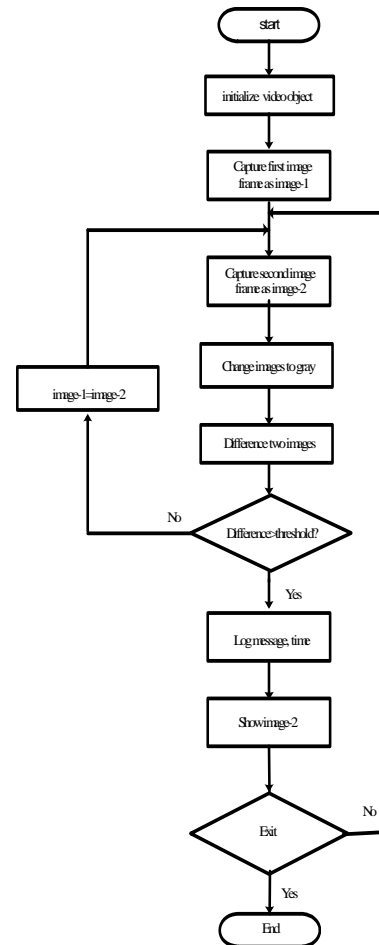

Fig. 3 Process flowchart

## V. EXPERIMENTAL RESULTS

The goal of this research is to produce a practical solution for a surveillance system. It has been accomplished with a unique solution, and the algorithm may be applicable to a variety of other problems in computer vision. In experiment procedure, the system is started with preview window as shown in Fig. 4. Previewing the video data can make sure that the image being captured is satisfactory. By looking at preview, whether the focus of the camera view is correct or not can be verified. In addition to the image, the preview window includes information about the image, such as time stamp of the video frame, the video resolution, and the current status of the video input object. If there is no change in the area of view, no frame will be captured in the motion panel.

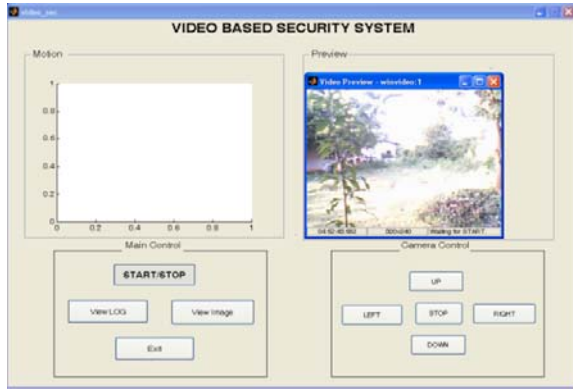

Fig. 4 The preview of the target area

When moving object enters the field of view, the scene will change. The system starts the process of detection and shows the detected frames sequentially. According to the operation, the scene of both the live video stream and the frame changes can be monitored simultaneously on GUI window. Fig. 5 shows the previewed image of the scene and the corresponding detected frame. The detected object entered the field of view is pointed out by oval shape in the motion panel of Fig. 5. Monitoring behaviour of people, objects or processes within system can be done by this



Fig. 5 Showing the detected image

application.

After stopping the system, the saved frame sequences can be viewed by surveillance staff. From this information, who entered the camera field of view and what he did in the field of view can be known. Because the image frames are stored in Audio Video Interleaved (AVI) format, the logged frames can be viewed in any standard media player. Fig. 6 shows the viewing image with movie format. This is one of the requirements for a surveillance system.



Fig. 6 Image with movie format

The system can save not only the detected frame sequences but also message (time information) precisely with text file for the surveillance staff. The operator can know the time of the detected object from the view log file and the elapsed time from command window. Fig. 7 is the detailed time information of the system.

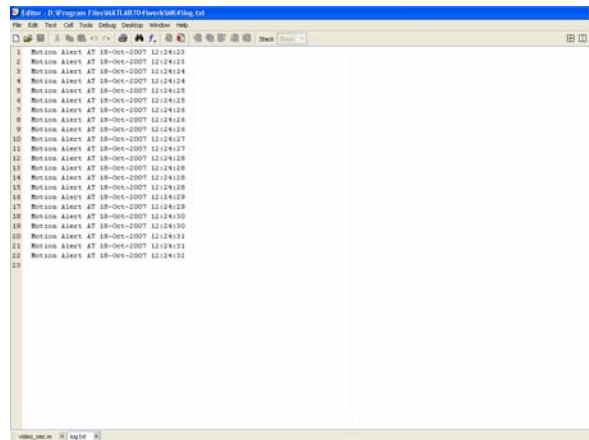

Fig. 7 View log file

## VI. CONCLUSIONS

This paper implements a system to monitor continuous live show the target area and to save the successive frame changes with software development. The system can detect the object

that enters the areas where the camera observed by changing the preset threshold value. To detect the motion in the target area, the system sets the appropriate threshold value. Since the variance is the pixel differences of two successive images, it is compared with the threshold value continuously to detect the difference of the two images. MATLAB software implementation is chosen for its simplicity and development power and its build-in functions. Since MATLAB offers an open configuration for software development, m-file is implemented to perform image difference. The GUI for the control software is modified to make the system more users friendly and beautiful. And also the operator can control the camera movement as any arbitrary direction from control buttons.

#### ACKNOWLEDGMENT

Firstly the author would like to thank her parents: U Win Mya and Daw Hninn Ngwe from Lashio, Myanmar for their encouragement and support. His Excellency Minister U Thaug, Ministry of Science and Technology will also get the author's great thanks for his special guidance to pay chances. Special thanks are due to her Supervisor, Professor Dr. Zaw Min Naing (Ph.D. (EEE) NTU, Singapore). The author especially thanks to her teachers at Yangon Technological University and Mandalay Technological University. The author greatly expresses her thanks to all persons whom will concern to support in preparing this paper.

#### REFERENCES

- [1] Wikipedia, the free encyclopedia, security.  
<http://en.wikipedia.org/wiki/Security>
- [2] Security Basics series: Security PACE Book 4-CCTV Systems and Control Design. <http://www.simplexgrinnell.com>
- [3] Image Acquisition Toolbox User's Guide, The Math Works, Inc. 2003-2007.
- [4] V.Zeljko, D.Pokrajac, "Motion Detection Based Multimedia Supported Intelligent Video Surveillance System" Applied Mathematics Research Center, Delaware State University, Dover, DE, USA
- [5] Yurong Li, "Motion Tracking in Active Vision System," M. Eng. thesis, B.S.E.E., University of Louisville, 1999